

INSPIRE  
YOUR  
IMAGINATION

BRIDGING  
TECHNOLOGY™

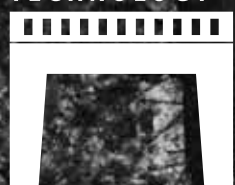

**Manfrotto**  
Imagine More

## BRIDGING TECHNOLOGY

The Manfrotto video solution combines ergonomics and exclusive design with professional performances for extra smooth shooting control.

**Cross over to the new dimension  
of film making.**

# Bridging Technology, an exclusive Manfrotto patent.

The perfect synthesis between an innovative  
“bridge architecture” and Manfrotto’s cutting  
edge engineering:

**Bridging Technology, an exclusive Manfrotto patent.**



# UNIQUE FEATURES FOR UNIQUE FOOTAGE



Longer sliding plate for extra balancing control.



Easy Link Connection to support V-DSRL and movie accessories.

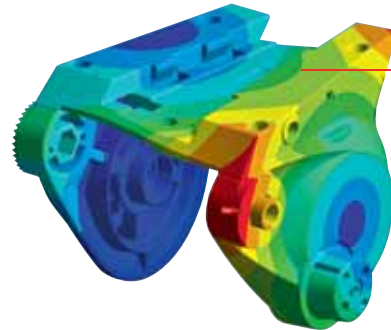

High rigidity structure

- 1 PAN fluid drag system for a more ergonomic operation
- 2 Easy Link Connectors for a more flexible accessory attachment
- 3 Wider top plate and longer sliding plate for extra stability and balance when using video or photo equipment
- 4 An even more rigid structure for maximum precision and improved responsiveness
- 5 Counterbalance system ensures quick set-up and optimal performance
- 6 Ball-bearing drag system for precise, smooth movements
- 7 Lightweight modern materials for optimum balance of strength and size
- 8 ABR (Advanced Balancing Recorder) for precision when fixing equipment, ensuring a perfect position, saving time and making this operation much more efficient, accurate and fast.

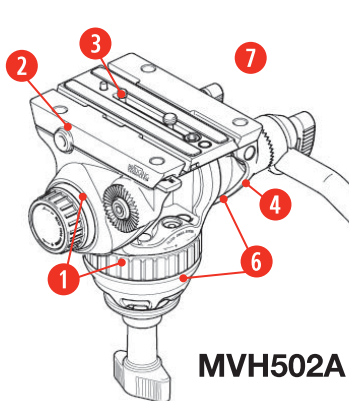



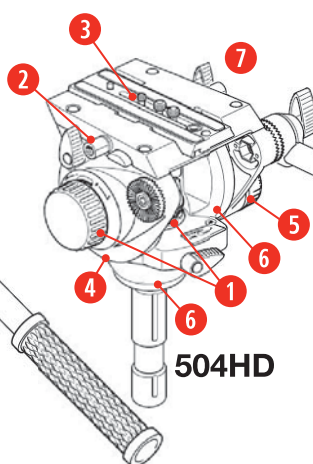



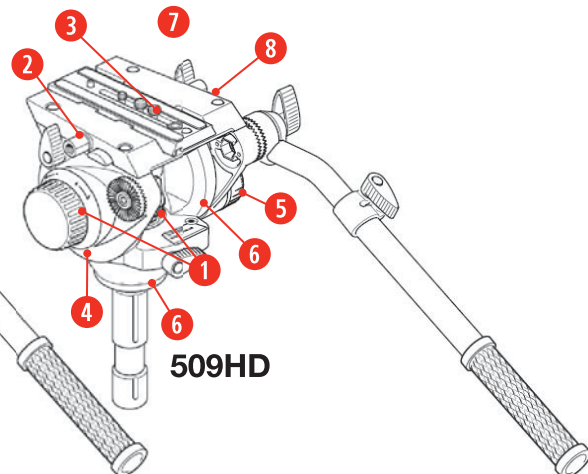



MVH502A



504HD



509HD

		MVH502A	504HD	509HD
				
	Fluidity PAN & TILT	Variable Fluid Cartridge	Variable Fluid Cartridge	Variable Fluid Cartridge
	Counterbalance System	fixed	4 steps	4 steps
		4kg - 8.8lb	7.5kg - 16.5lb	13kg - 28.8lb
	Leveling bowl	Ø 75mm	Ø 75mm	Ø 100mm
	ABR (Advanced Balancing Recorder)	N.A.	N.A.	Available
	Sliding Plate	Long	Long	Long
		(140mm - 5.5in)	(140mm - 5.5in)	(140mm - 5.5in)
	Easy Link Connectors	Available x 2	Available x 2	Available x 2
	Leveling Bubble	Available	Available (illuminated)	Available (illuminated)
	Material			

KEY TO SYMBOLS



# BRIDGING TECHNOLOGY™

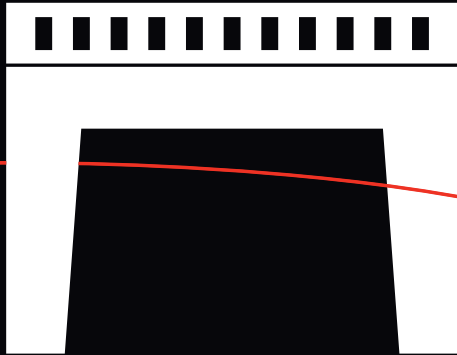

Video industry technology has radically changed over the past few years, introducing even lighter and more compact cameras. The latest cameras have created a new way of filming, where one person is often able to do the job on their own while a few years ago a full crew was required.

## **The video industry is crossing over to a new dimension!**

Manfrotto, a market leader in the light video camera and photographic supports, is launching a new family of video systems developed specifically for the latest camcorders, 3D rigs and the new generation V-DSLR. The ergonomic and technical characteristics make these systems the perfect support for the “new” video industry.

## **NEW BRIDGING SYSTEMS**

Manfrotto is proud to introduce the “500” series with an invitation to “cross over” to the new dimension of film making. This family is the result of an important technical evolution the perfect synthesis between an innovative “bridge architecture” and Manfrotto’s cutting edge engineering: Bridging Technology, an exclusive Manfrotto patent. A new platform leading the videographer and photographer to even better results with today’s high-definition cameras.

# TWIN LEG SYSTEMS

The priority of our new systems is to provide a complete package for video support. Our new twin leg tripods are an ideal combination for the Bridging heads and are available in two versions: with a mid-level spreader or with a ground level spreader.

## 1 LEVELING SYSTEM

The head leveling system is built around a 100mm and 75mm bowl which guarantees perfect stability at any angle.

## 2 LEG LOCK LEVERS

Our new leg lock levers have been designed to improve ergonomics and speed up deployment and adjustment. Optimum performance for tripod payloads up to 25kg/55.1lb.

## 3 LOCKING COLLAR POWER ADJUSTMENT

Another detail of the care that goes in to ensuring your Manfrotto tripod will outlast the competition: the screws behind all the collars on each leg allow you to adjust the overall locking power throughout the tripod's life, so even after years of heavy use, it can be as sturdy and reliable as the day you got it.

## 4 TELESCOPIC SPREADER

Important improvements have been made to the mid-level spreader, which is now re-engineered and more robust, guaranteeing a flexible link between the spreader and tripod leg. A ground telescopic spreader is also available.

## 5 GRIP

Perfect grip on any terrain thanks to the spiked feet with removable rubber shoes (545 and 546 series).

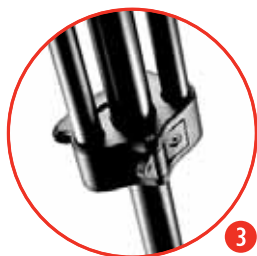

**509HD  
SYSTEMS**







509HD, 545BK







509HD, 545GBK

**509HD, 545BK SYSTEM**

			
13kg 28.6lb	45cm 17.7in	169cm 66.5in	8.2kg 18lb

**509HD, 545GBK SYSTEM**

			
13kg 28.6lb	47.5cm 18.7in	173.5cm 68.3in	8.1kg 17.8lb

**504HD  
SYSTEMS**







504HD, 546BK SYSTEM







504HD, 546GBK SYSTEM

**504HD, 546BK SYSTEM**

			
7.5kg 16.5lb	44cm 17.3in	167.5cm 65.9in	6.3kg 13.9lb

**504HD, 546GBK SYSTEM**

			
7.5kg 16.5lb	46.5cm 18.3in	171cm 67.3in	6.3kg 13.9lb

**MVH502A  
SYSTEMS**







MVK502AM







MVH502A, 546BK

**MVK502AM SYSTEM**

			
4kg 8.8lb	63cm 24.8in	157cm 62in	4kg 8.8lb

**MVH502A, 546BK SYSTEM**

			
4kg 8.8lb	44cm 17.3in	168cm 66.1in	5.5kg 12.1lb

# SINGLE CARBON LEG SYSTEMS

Simple words for an exceptionally flexible Manfrotto system. The combination of the head family with a single-leg carbon fiber tripod offers the ultimate in lightweight support, with a resistance to torsion that even outperforms twin-leg aluminum tripods. Not forgetting the incredible min-max height range this design allows: from 40cm (15.7in) to 217.5cm (85.6in)... all from a single system. Ideal for new DSLR-Video cameras.









## 509HD SYSTEM



509HD, 536K

### 509HD, 536K SYSTEM

 max			
13kg 28.6lb	42cm 16.5in	218cm 85.8in	7.9kg 17.4lb

## 504HD SYSTEMS







504HD, 535K







504HD, 536K

### 504HD, 535K SYSTEM

 max			
7.5kg 16.5lb	40.5cm 15.9in	184cm 72.4in	5kg 11lb

### 504HD, 536K SYSTEM





 max			
7.5kg 16.5lb	40cm 15.7in	217.5cm 85.6in	6.1kg 13.4lb

## MVH502A SYSTEM



MVK502C

### MVK502C SYSTEM

 max			
4kg 8.8lb	41cm 16.2in	185cm 72.8in	4.3kg 9.5lb

The skills of the world's best photographers and video operators are brought together by Manfrotto in an innovative on-line platform.

Featuring:

Harry De Zitter,  
Bill Frakes,  
Joe McNally,  
Drew Gardner,  
Roberto Bigano,  
Ami Elsius,  
Marc de Tollenaere,  
Kristoff Ramon,  
David Duchemin,  
Milko Marchetti,  
Uri Golman,  
Adam Barker,  
Kazuyuki Okajima and many others.



**Manfrotto**  
SCHOOL OF XCELLENCE  
[manfrottoschoolofexcellence.com](http://manfrottoschoolofexcellence.com)